

The 2nd International Conference on Rehabilitation and Maintenance in Civil Engineering

Self-Compacting Concrete with Recycled Traditional Roof Tile Powder

Bernardinus Herbudiman^{a*} and Adhi Mulyawan Saptaji^a

^aDept. of Civil Engineering, Institut Teknologi Nasional, Bandung, Indonesia

Abstract

Bad reinforcement concrete works could generate building failures after earthquake. Concrete pouring and compacting on structural element with dense reinforcement and beam column joint are difficult. Suitable solution on this problem is the use of self-compacting concrete that has flow-ability, filling-ability, and passing-ability. Traditional roof tile waste is available in Indonesian villages. The use of traditional roof tile powder in self-compacting concrete is an effort to recycle waste and new development in environmental friendly concrete material technology. This research tends to understanding contribution of traditional roof tile powder in development of workability and strength of self-compacting concrete. On this research, self compacting concretes are designed as follows: 1) water-powder ratio (w/p) is designed with 0.35, 0.32, and 0.29; 2) maximum dimension of coarse aggregate is limited by 15 and 20 mm; 3) dosages of traditional roof tile powder are 0%,10%,20%, and 30% from powder weight; 4) dosage of silica fume sets to be 5% for all trial mixes; 5) super-plasticizer is added with dosage of 0.5%, 1.0%, 1.2% and 1.5% from powder weight to achieve flow characteristic of self compacting concrete; 5) aggregates are washed before mixing. Indonesian standard (SNI 03-2834-2000) combined with simple mix design Okamura are used to calculate the compositions of self-compacting concrete. Test on fresh concrete is slump spread for all trial mixes. The mix that has the largest slump spread is tested with V-funnel and L-shaped box. Specimens of cylinder with diameter of 10 cm and height of 20 cm are used in this research to determine the compressive strength and split-tensile strength. Maximum diameter of slump spread could achieve 65 cm. Duration in V-funnel test is 14.6 second. In L-shaped box, duration to reach 40 cm and to reach box-end are 45 and 65 second, respectively. Blocking/passing ratio (H2/H1) is 4.5/32. Optimum dosage of traditional roof tile powder is 20% at w/p of 0.35 and dosage of super-plasticizer of 1% that has compressive strength of 44.11 MPa and split-tensile strength of 3.25 MPa. Washing aggregate before mixing could increase workability performance and increase compressive and split-tensile strength of 17.06 % and 42.37 %. Coarse aggregate with maximum dimension of 20 mm has compressive strength of 51.05 MPa. Optimum w/p is 0.32 and optimum dosage of super-plasticizer is 1.5% at dosage of traditional roof tile powder of 20%, dosage of silica fume of 5%, and proportion of coarse aggregate of 45% that has the largest compressive strength of 67.72 MPa.

Keywords: self-compacting concrete; traditional roof tile powder; slump spread.

1. Introduction

Recently, development on concrete technology grows to satisfy the needs to make higher performance concrete. Self-compacting concrete (SCC) is well known as an

* Corresponding author.

E-mail address: herbudiman@itenas.ac.id; herbudimanb@yahoo.com

innovation on concrete technology.

SCC capability to flow with high flow-ability makes the fresh concrete is not need compaction and then suitable to use in structure elements which have dense reinforcement. This characteristic also generates easier workability, reduce the need of large number workmanships, and reduce duration of concrete construction stage.

Okamura introduce self-compacting concrete (SCC) in Japan and makes the SCC popular, fast developed, and widely applicable especially on pre-cast concrete due to its cost reduction (Okamura and Ozawa 1994).

Self-compacting concrete (SCC) conventionally consists of powder (portland cement, silica fume, and fly ash), fine and coarse aggregates, superplasticizer, and water. On this research, powder component is rather different with the conventional SCC. Recycled traditional roof tile powder from local production waste and residential waste is used as powder component to replace fly ash in conventional SCC.

There are two major reasons to select traditional roof-tile powder as powder component in SCC. First, this powder available as residential waste in Indonesia, and the use this waste as recycled material give positive impact to its environment. Second, this waste has silica content then potentially could be used as pozzolanic material. As pozzolanic material, this waste could be a good binder and also a good filler agents. With suitable trial mix composition, traditional roof-tile powder could improve quality and flowability of self-compacting concrete.

Self-compacting concrete (SCC) need additive material to provide high workability and high flowability. This additive material is superplasticizer which have several type due to application need. Superplasticizer has capability to reduce water content up to 30% then could optimize cement content and other binder agents. Unfortunately, superplasticizer is expensive and the use on high dosage application could generate bleeding and segregation. Consider the advantages and disadvantages, trial on dosage of superplasticizer in concrete mix-design is needed to get optimum dosage of superplasticizer which could reach high flowability and high concrete strength.

Aggregate is important material in concrete due to its interlocking contribution to concrete strength. Clay content on aggregate could generate weakness bonding between aggregate and concrete paste and then could reduce concrete strength. Agreggate with high clay content need several treatment such as washing. The influence of washing process on aggregate to the concrete performance is determined in this research.

Dimension of coarse aggregate also affect the fresh concrete flow and concrete strength. On this research, two type of aggregates are used, split $\frac{1}{2}$ and aggregate with dimension of 10-15 mm. Two dimensions of coarse aggregate and its influence to the concrete performance is compared in this research.

Water-per-powder ratio (w/p) also affect the concrete performance. Less w/p could increase concrete performance, but could decrease concrete flow. On this research, optimum w/p is developed to gain best option on both concrete strength and fresh concrete flow.

Development on concrete strength is also determined in this research by observe the 7, 14, and 28 days concrete compressive strengths.

2. Self Compacting Concrete

Self compacting concrete has small volume of pore in concrete then could minimize amount of captured air in concrete. Refer to its name; self compacting concrete could be defined as concrete which could compact by its self-weight without vibrator help.

Self compacting concrete has different material composition and visual appearance compared with normal concrete. Comparison of material composition between self compacting concrete and normal concrete are shown on Figure 1 (Nugraha and Antoni, 2007). Proportion of coarse aggregate on self compacting concrete is less then normal concrete. On self compacting concrete, cement content is replaced with powder, which conventionally consists of Portland cement, silica fume and fly ash. Proportions of water and sand on both types of concrete are relatively same.

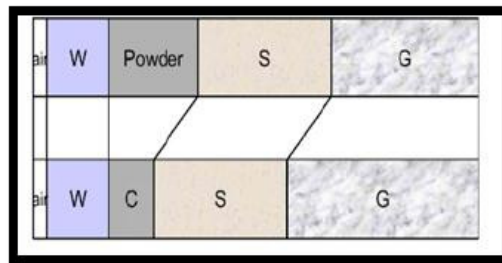

Note : W: Water; C: Cement; S: Sand; G: Gravel

Figure 1. Comparison of material composition between self compacting concrete (up) and normal concrete (bottom)
(Nugraha and Antoni, 2007)

Self compacting concrete has several direct advantages, such as: reach difficult place on building, prevent bleeding and segregation, minimize amount of infiltrate water on concrete which could generate corrosion on reinforcement, give protection against external factors. Self compacting concrete has several indirect advantages, such as: reduce problems from vibration process, minimize numbers of workmanship, increase construction process, increase quality and durability, and also increase strength and performance.

Design mix of self compacting concrete is different with the normal concrete. Okamura (1994) introduce a simple mix design. Amount of coarse and fine aggregates are determined first, then self compacting characteristics could be developed by set water-per-powder ratio and dosage of super-plasticizer. The specifications are: (1) coarse aggregate set by 50% of solid volume to make mortar could flow on the void between coarse aggregates; (2) volume of fine aggregate is determined as 40% of total volume mortar, which has purpose to fill the void between coarse aggregates; (3) low water-per-powder ratio; and (4) high dosage of super-plasticizer.

On normal concrete, water-per-cement ratio is used to determined concrete strength. On self compacting concrete, water-per-powder ratio is used to determine self compacting characteristic. This ratio directly affects the fresh concrete characteristic, and the strength is positioned as quality control parameter.

Mix design of self compacting concrete should achieve three requirements: (1) flowability, (2) passingability, and (3) segregation resistance.

Self compacting concrete is designed and is tested to meet project needs. Its capability to flow makes this fresh concrete to be pumped and be flowed by pipe. This capability is very helpful on project site to pouring on high elevation. This fresh concrete also could be poured with more than 2-meters fall elevation due to its segregation resistance.

Brouwers and Radix (2005) show material composition of self compacting concrete as shown on Figure 2.

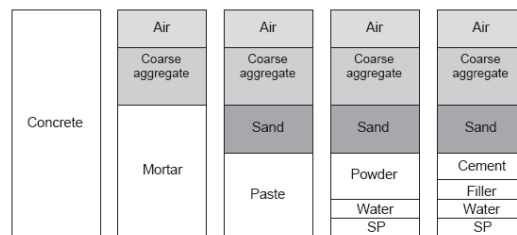

Figure 2: Material composition of self compacting concrete
(Brouwers and Radix, 2005)

Figure 2 show the concrete consists of air, coarse aggregate and mortar. The mortar consists of sand and paste. The paste consists of powder, water, and super-plasticizer. Finally, the powder on self compacting concrete consists of cement and filler.

Powder has particle dimension of 0.125 mm or pass the No. 100 sieve and potentially has capabilities to be a binder and filler. On conventional self compacting concrete, powder consists of Portland cement, fly ash and silica fume. On this research, the fly ash is replaced by recycled traditional roof tile powder.

Requirements of self compacting concrete refer to the European Guidelines for Self Compacting Concrete (2005) is shown on Table 1.

Table 1. Requirements of self compacting concrete refer to the European Guidelines for Self Compacting Concrete (2005)

No.	SCC requirements	Range
1	Diameter of slump flow	min. 500 mm
2	V- Funnel	8-15 second
3	L- Shaped Box (H_2/H_1)	> 0.8
4	w/p ratio	0.25 - 0.40
5	Compressive strength 28-days	min. 40 MPa
6	Split-tensile strength 28-days	min. 2.4 MPa

Slump flow test is a method to get flow-ability characteristics of self-compacting concrete without any segregation. As slump test method, slump flow test method also use Abram's cone, but has different measured parameter. On this slump flow test, diameter of fresh concrete spread is measured. Sketch of measured spread diameter of fresh concrete and slump flow test are shown on Figure 3.

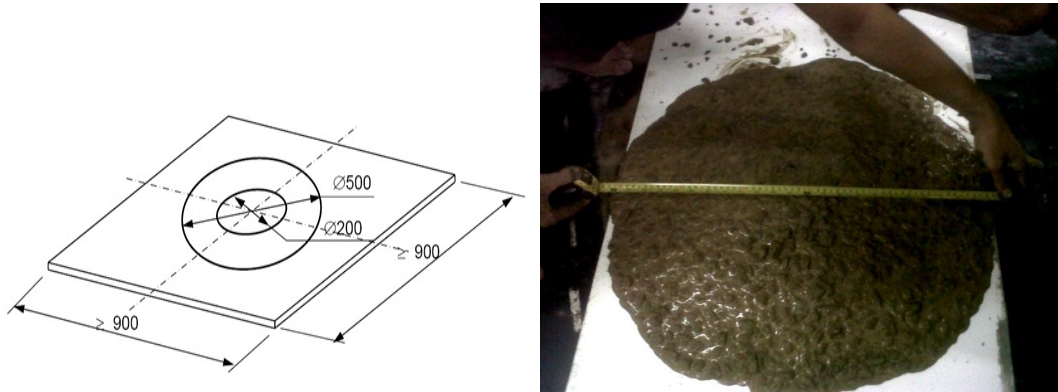

Figure 3. Slump flow test

V-funnel test is a test on fresh self compacting concrete to determine the viscosity, filling-ability and segregation resistance of fresh concrete. Design of the shape of V-funnel is tend to indicate any blocks on fresh concrete. If composition of concrete consists a lot of coarse aggregate, fresh concrete need longer duration to flow. Sketch of V-funnel tool and test are shown on Figure 4.

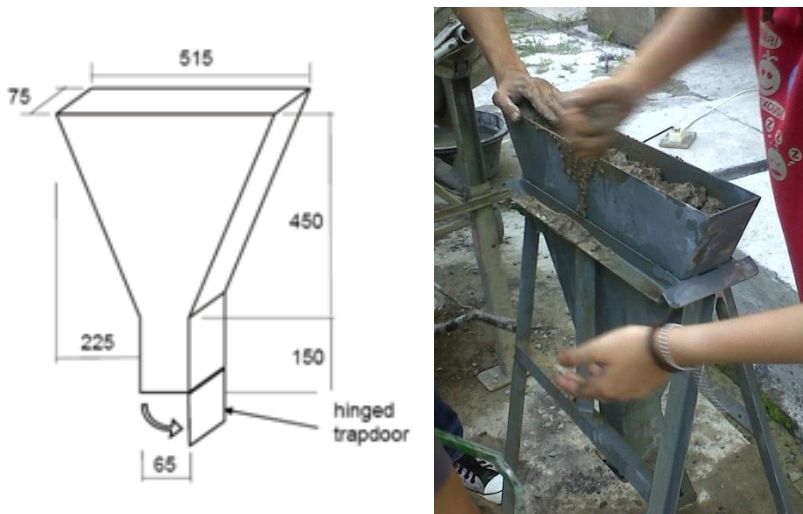

Figure 4. V-Funnel test

L-shaped box test is a method to determine passing-ability of fresh concrete to pass dense reinforcement block and thin slim member. Several reinforcement bars are modeled as blocks on L-shaped box. Blocking-per-passing ratio is measured by H_1 and H_2 as shown on Figure 4a. The L-shaped box test is shown on Figure 4b.

After several tests, fresh concrete is poured on 100-mm-diameter, 200-mm-height cylinder molds.

After 28-days wet curing, cylinder concretes are tested on universal testing machine (UTM) to determine compressive strength as shown on Figure 5, and split-tensile strength as shown on Figure 6.

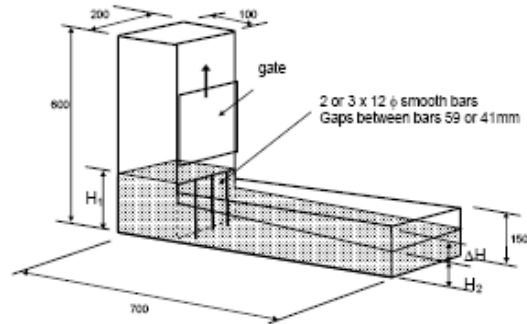

Figure 4. L-Shaped Box



Figure 5. Compression test



Figure 6. Split-tensile test

3. Methodology

3.1. Tests of Aggregates

Physical characteristics of fine and coarse aggregates are determined first as follow:

Physical characteristics of fine aggregate based on tests under ASTM guidance are as follows: fineness modulus 3.69; water content (%) 8.22; absorption (%) 2.04; weight of loose volume (gram/cm^3) 1.53; weight of dense volume (gram/cm^3) 1.63; bulk specific-gravity on saturated surface dry condition 2.53; and clay content (%) 8.50.

Physical characteristics of coarse aggregate are: fineness modulus 6.94; water content (%) 2.32; absorption (%) 1.66; weight of loose volume (gram/cm^3) 1.33; weight of dense volume (gram/cm^3) 1.42; bulk specific-gravity on saturated surface dry condition 2.60; clay content (%) 0.80; and maximum diameter (mm) 20.

3.2. Mix Design

The purpose of concrete design mix is to determine concrete composition which could reach design strength and workability.

On this research, methods for concrete mix design are base on Indonesian code for normal concrete design mix (SNI 03-2834-2000) and modified with simple mix design Okamura. The modifications are created on fine and coarse aggregates proportion, and reducing water content caused by the use of super-plasticizer.

For water-per-powder ratio (w/p) of 0.35, and amount of coarse aggregate is 50% of its volume-weight, the steps for design mix are as follow: type of cement: Portland Composite Cement type-1; type of coarse aggregate: split; type of fine aggregate: Galunggung sand; free water-per-cement ratio: 0.35; design slump: 10-30 mm; maximum diameter of coarse aggregate: 20 mm; free water content: $180 \text{ kg}/\text{cm}^3$; cement content: $514.286 \text{ kg}/\text{cm}^3$; zone of fine aggregate gradation: Zone-2; specific gravity of combined aggregate on saturated surface dry condition: 2.6; volume-weight of concrete, based on Figure 16 SNI 03-2834-2000: $2450 \text{ kg}/\text{cm}^3$; amount of combined aggregate:

1755.7 kg/cm³; amount of coarse aggregate, based on maximum 50% of solid volume (Okamura): 877.85 kg/cm³; and amount of fine aggregate: 877.5 kg/cm³.

After the first trial, several modification trial mixes are created as follow:

Modification-1 is observed on specimen I, II, and III. Parameter which set to be fix are water-per-powder ratio (w/p) of 0.35, amount of cement of 75%, amount of silica fume of 5%, amount of traditional roof-tile powder of 20%, amount of coarse aggregate of 50%, water content of 180 kg/cm³. The variable parameter is dosage of super-plasticizer which vary from 0.5%, 1%, up to 1.5%.

Modification-2 is observed on specimen IV, V, II, and VI. Parameter which set to be fix are water-per-powder ratio (w/p) of 0.35, amount of silica fume of 5%, dosage of super-plasticizer of 1%, amount of coarse aggregate of 50%, water content of 180 kg/cm³. The variable parameter is amount of traditional roof-tile powder which vary from 0%, 10%, 20% up to 30%. This increment amount of traditional roof-tile powder is correlated with the decrement of cement content from 95%, 85%, 75%, until 65%.

Modification-3 is observed on specimen VII, and VIII. Parameter which set to be fix are water-per-powder ratio (w/p) of 0.35, amount of cement of 75%, amount of silica fume of 5%, amount of traditional roof-tile powder of 20%, amount of coarse aggregate of 45%, water content of 180 kg/cm³, and the dosage of super-plasticizer of 1.2%. The variable parameter is the different condition of the fine and the coarse aggregates, not be washed, and be washed.

Modification-4 is observed on specimen VIII, and IX. Parameter which set to be fix are same with Modification-3. The variable parameter is the different fraction of the coarse aggregates, split ½ and split 10-15mm.

Modification-5 is observed on specimen VIII, X, XI, and VIII. Parameter which set to be fix are amount of cement of 75%, amount of silica fume of 5%, amount of traditional roof-tile powder of 20%, amount of coarse aggregate of 45%, water content of 180 kg/cm³. The variable parameter is water-per-powder ratio (w/p) of 0.35, 0.32, 0.32, and 0.29. Correlated dosages of super-plasticizer with the w/p are 1.2, 1.2, 1.5, and 1.5%, respectively.

4. Results and Discussion

Compositions of self-compacting concrete with traditional roof-tile powder and its experimental results are shown on Table 2.

Table 2 shows the small diameter slump spread of fresh concrete from trial mix I until VI caused by high proportion of coarse aggregate as 50 % from its solid volume. High proportion of coarse aggregate makes concrete paste not enough surround the aggregate surface, then self-compacting characteristic is not easy to be achieved. Base on this fact, reduction on proportion of coarse aggregate until 45% is generated on trial mix VII until XI. The diameter slump spread of fresh concrete from trial mix VII until XI then increased.

Table 2 shows the largest slump spread of fresh concrete is 65 cm on trial mix XI.

On trial mix XII, degradation of slump spread is happened. With relative small water-per-powder ratio (w/p) of 0.29, concrete mix could not satisfy the self-compacting characteristic.

Influence of dosage of super-plasticizer to the concrete performance is shown on Table 3. Influence of dosage of traditional roof-tile powder to the concrete performance is shown on Table 4.

Strength developments of SCC with traditional roof-tile powder are shown on Table 5. Comparison of strength development of SCC with normal concrete is shown on Figure 7.

Table 2. Compositions of SCC with traditional roof-tile powder and its experimental results

No	Mix	Cement (kg/m ³)	Roof-Tile Powder (kg/m ³)	Silica Fume (kg/m ³)	Fine aggregate (kg/m ³)	Coarse aggregate (kg/m ³)	Water (l/m ³)	Super-plasticizer (l)	w/p ratio	Slump Spread (mm)	Compressive strength (MPa)	Split-tensile strength (MPa)
1	I	385.714	102.857	25.714	891.566	710	180	2.571	0.35	400	40.36	2.79
2	II	385.714	102.857	25.714	885.055	710	180	5.143	0.35	540	44.11	3.25
3	III	385.714	102.857	25.714	878.544	710	180	7.714	0.35	500	38.51	2.71
4	IV	488.571	0	25.714	890.834	710	180	5.143	0.35	510	39.06	2.71
5	V	437.143	51.429	25.714	891.945	710	180	5.143	0.35	520	42.78	2.87
6	VI	334.286	154.286	25.714	878.165	710	180	5.143	0.35	500	37.13	2.62
7	VII	385.714	102.857	25.714	951.593*	639*	180	6.171	0.35	550	42.34	3.25
8	VIII	385.714	102.857	25.714	951.593	639^	180	6.171	0.35	570	51.05	2.38
9	IX	385.714	102.857	25.714	951.593	639**	180	6.171	0.35	560	50.21	-
10	X	421.875	112.500	28.125	909.245	639	180	6.750	0.32	620	59.53	-
11	XI	421.875	112.500	28.125	904.972	639	180	8.438	0.32	650	67.72	-
12	XII	465.517	124.138	31.034	853.420	639	180	9.310	0.29	400	55.70	-

Note : *) Aggregates not be washed; ^) Aggregates be washed, split 1/2; **) Split 10-15 mm.

Table 3. Influence of dosage of super-plasticizer to the concrete performance

Mix	Cement (kg/m ³)	Roof-Tile Powder (kg/m ³)	Silica Fume (kg/m ³)	Fine aggregate (kg/m ³)	Coarse aggregate (kg/m ³)	Water (l/m ³)	Super-plasticizer (%)	Super-plasticizer (l)	w/p ratio	Slump Spread (mm)	Compressive strength (MPa)	Split-tensile strength (MPa)
I	385.714	102.857	25.714	891.566	710	180	0.5	2.571	0.35	400	40.36	2.79
II	385.714	102.857	25.714	885.055	710	180	1.0	5.143	0.35	540	44.11	3.25
III	385.714	102.857	25.714	878.544	710	180	1.5	7.714	0.35	500	38.51	2.71

Table 4. Influence of dosage of traditional roof-tile powder to the concrete performance

Mix	Cement (kg/m ³)	Roof-Tile Powder (%)	Roof-Tile Powder (kg/m ³)	Silica Fume (kg/m ³)	Fine aggregate (kg/m ³)	Coarse aggregate (kg/m ³)	Water (l/m ³)	Super-plasticizer (l)	w/p ratio	Slump Spread (mm)	Compressive strength (MPa)	Split-tensile strength (MPa)
IV	488.571	0	0	25.714	890.834	710	180	5.143	0.35	510	39.06	2.71
V	437.143	10	51.429	25.714	891.945	710	180	5.143	0.35	520	42.78	2.87
II	385.714	20	102.857	25.714	885.055	710	180	5.143	0.35	540	44.11	3.25
VI	334.286	30	154.286	25.714	878.165	710	180	5.143	0.35	500	37.13	2.62

Table 5. Strength development of SCC with traditional roof-tile powder

Mix	Cement (kg/m ³)	Roof-Tile Powder (kg/m ³)	Silica Fume (kg/m ³)	Fine aggregate (kg/m ³)	Coarse aggregate (kg/m ³)	Water (l/m ³)	Super-plasticizer (l)	w/p ratio	Slump Spread (mm)	Compressive strength 7-days (MPa)	Compressive strength 14-days (MPa)	Compressive strength 28-days (MPa)
VIII	385.714	102.857	25.714	951.593	639	180	6.171	0.35	570	28.15	42.34	51.05
X	421.875	112.500	28.125	909.245	639	180	6.750	0.32	620	37.10	48.95	59.53
XI	421.875	112.500	28.125	904.972	639	180	8.438	0.32	650	49.97	52.77	67.72
XII	465.517	124.138	31.034	853.420	639	180	9.310	0.29	400	43.85	48.43	55.70

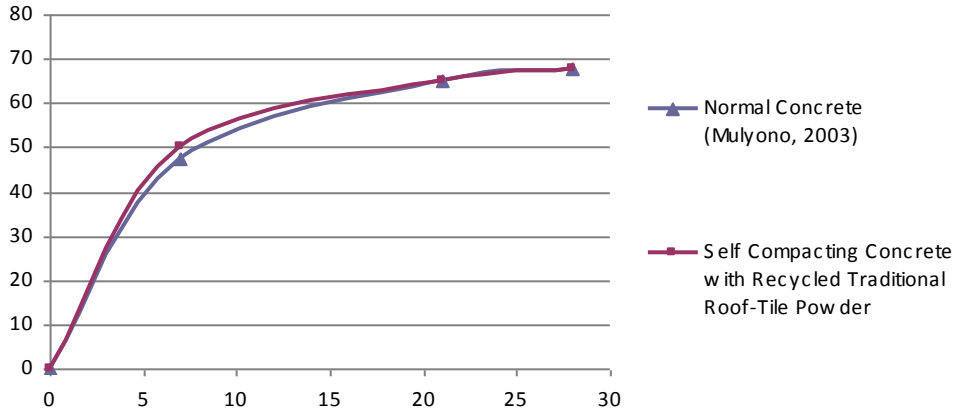

Figure 7. Comparison of strength development of SCC with normal concrete

Trial mix XI which has maximum slump spread, then be tested on V-funnel and L-shaped box. Duration to pass V-funnel test is 14.6 second which lied on the requirement range of 8-15 seconds, then indicates fresh concrete has good flow-ability. On the L-shaped box test, duration to reach 40 cm from the inner side of L-shaped box is 30 second and blocking-per-passing ratio (H_2/H_1) is 4.5/32. Unfortunately, the blocking-per-passing ratio < 0.8 shows the fresh concrete still has difficulty to pass dense reinforcement.

The trial mix XI also has maximum concrete compressive strength of 67.72 MPa.

Table 3 shows the optimum dosage of super-plasticizer is 1%, which give compressive and split-tensile strength of 44.11 and 3.25 MPa, respectively.

Table 4 shows the optimum amount of traditional roof-tile powder is 20% which correlated with the cement content of 75%. This composition gives compressive and split-tensile strength of 44.11 and 3.25 MPa, respectively.

Table 2 shows the washing process could increase concrete compressive and split-tensile strengths up to 17% and 42%, respectively. Table 2 also shows that the concrete strength influenced by the coarse aggregate dimension.

Figure 7 shows that the self-compacting concrete with traditional roof-tile powder has same type of strength development with the normal concrete.

5. Conclusion

From the results and discussions, several conclusions could be summarized as follow:

Trial mix with has parameter as follow: amount of cement of 75%, amount of silica fume of 5%, amount of traditional roof-tile powder of 20%, amount of coarse aggregate of 45%, water content of 180 kg/cm³, w/p of 0.32; correlated dosages of super-plasticizer of 1.5, has the largest slump spread of fresh concrete of 65 cm, and the largest concrete compressive strength of 67.72 MPa. This fresh concrete also indicates good flow-ability by V-funnel test, but still has difficulty to pass dense reinforcement by L-shaped box test.

On the w/p of 0.35, amount of cement of 75%, amount of silica fume of 5%, amount of traditional roof-tile powder of 20%, amount of coarse aggregate of 50%, water content of 180 kg/cm³, the optimum dosage of super-plasticizer is 1%, which give compressive and split-tensile strength of 44.11 and 3.25 MPa, respectively.

On the w/p of 0.35, amount of silica fume of 5%, dosage of super-plasticizer of 1%, amount of coarse aggregate of 50%, water content of 180 kg/cm³, the optimum amount of traditional roof-tile powder is 20% which correlated with the cement content of 75%. This composition gives compressive and split-tensile strength of 44.11 and 3.25 MPa, respectively.

The washing process could increase concrete compressive and split-tensile strengths up to 17% and 42%, respectively. The concrete strength also influenced by the coarse aggregate dimension.

The self-compacting concrete with traditional roof-tile powder has same type of strength development with the normal concrete.

References

- ASTM C127-07, Standard test Method for Density, Relative Density (Specific Gravity), and Absorption of Coarse Aggregate.
- ASTM C339-86 "Standard Test Method for Compressive Cylindrical Concrete Specimen" [ASTM, 1993].
- Brouwers, Radix, 2005, Cement and Concrete Research. [Online]. Available : <http://digilib.petra.ac.id>.
- Nugraha, P., dan Antoni, 2007, Teknologi Beton dari Material, Pembuatan, ke Beton Kinerja Tinggi, Andi, Jakarta.
- Okamura, H., and Ozawa, K., 1994. Self-Compactable High Performance Concrete, American Concrete Institute, Detroit.
- Okamura, H., and Ouchi, M. 2003, Self-Compacting Concrete, Journal of Advanced Concrete Technology Vol 1, No 1, 5-15.
- SNI 03-2834-2000, 2000, Tata Cara Pembuatan Rencana Campuran Beton Normal, Badan Litbang PU.
- The European Guidelines, 2005, for Self-Compacting Concrete.

